

THIS DOCUMENT IS THE PROPERTY OF WANG LABORATORIES, INC. AND SHALL NOT BE REPRODUCED OR COPIED, OR USED AS A BASIS FOR THE MANUFACTURE OR SALE OF APPARATUS OR DEVICES WITHOUT PERMISSION.

HOLE LEGEND		
DRILLER	DATE	TOL.
REWORKER	11/18/64	1/32"
TOLERANCE:		±0.001"
REV.	DESCRIPTION	QTY.
A		

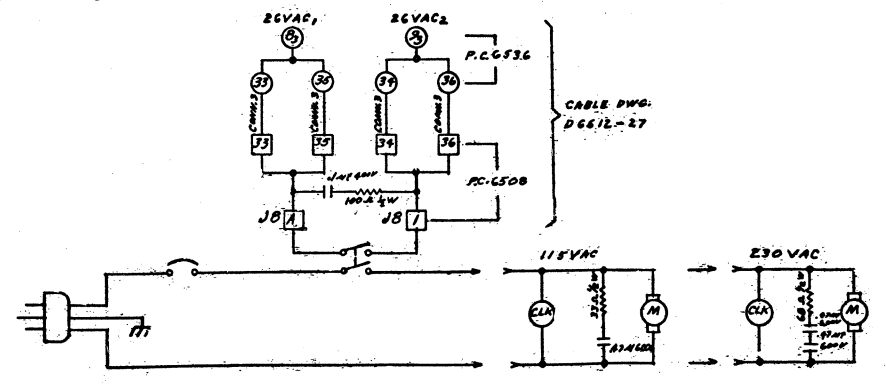
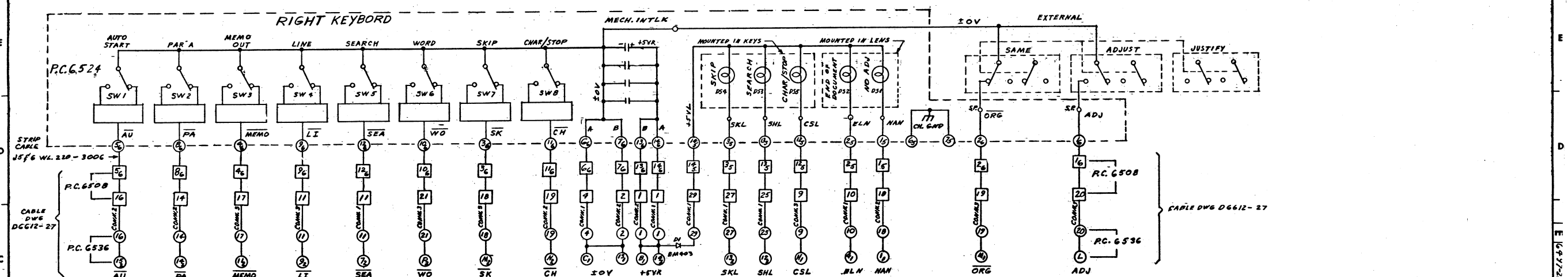
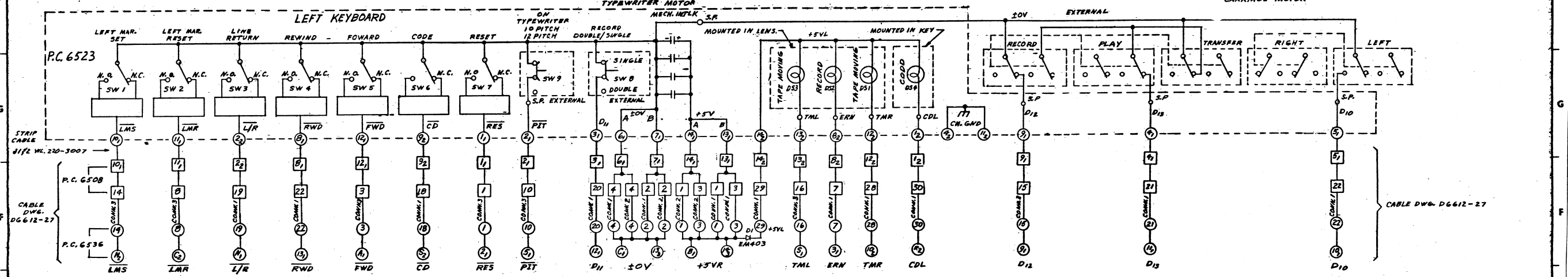
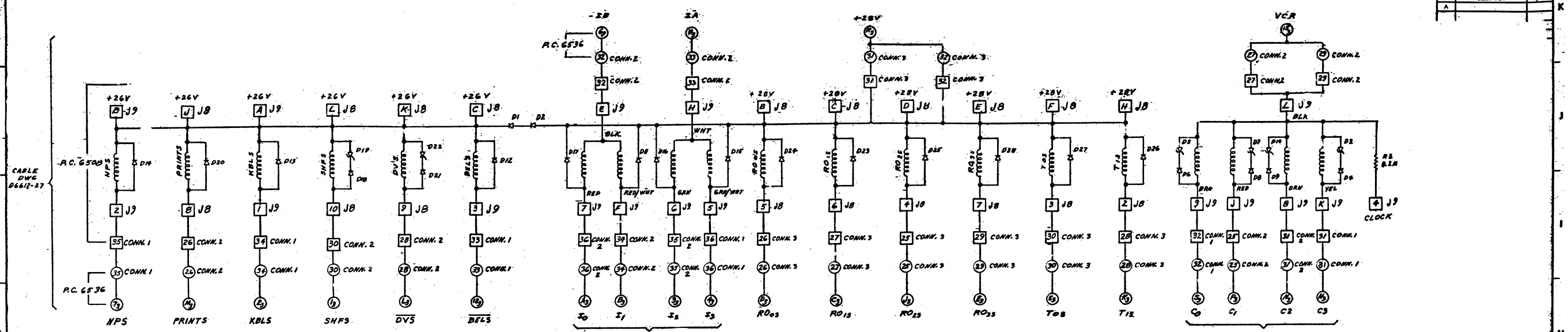

SHEET 2 IN D SIZE

WANG PART NO.	ITEM	QTY.	NAME	MATERIAL	DESCRIPTION
1222					
MATERIAL			TITLE		
FINISH			DATE		

WANG LABORATORIES, INC.		DATE	APPROVED BY	DATE
DESIGNED BY	CHK.	11/18/64	E. ENGR. J.P.	11/18/64
E. C. CONTROL	MFG ENGR.			

NO.	REVISION	DATE	BY	DESCRIPTION
1	1			SCHEMATIC TYPEWRITER WIRING

6497-200

THIS DOCUMENT IS THE PROPERTY OF WANG LABORATORIES, INC. AND SHALL NOT BE REPRODUCED OR COPIED, OR USED AS A BASIS FOR THE MANUFACTURE OR SALE OF APPARATUS OR DEVICES WITHOUT PERMISSION.

HOLE LEGEND		
DRILLED OR PUNCHED HOLE TOLERANCES:	HOLE DIA	TOL
	0.135 to 1.25	±.003
	1.26 to 2.50	±.004
	2.51 to 5.00	±.005

IDENT	DESCRIPTION	QTY
A		

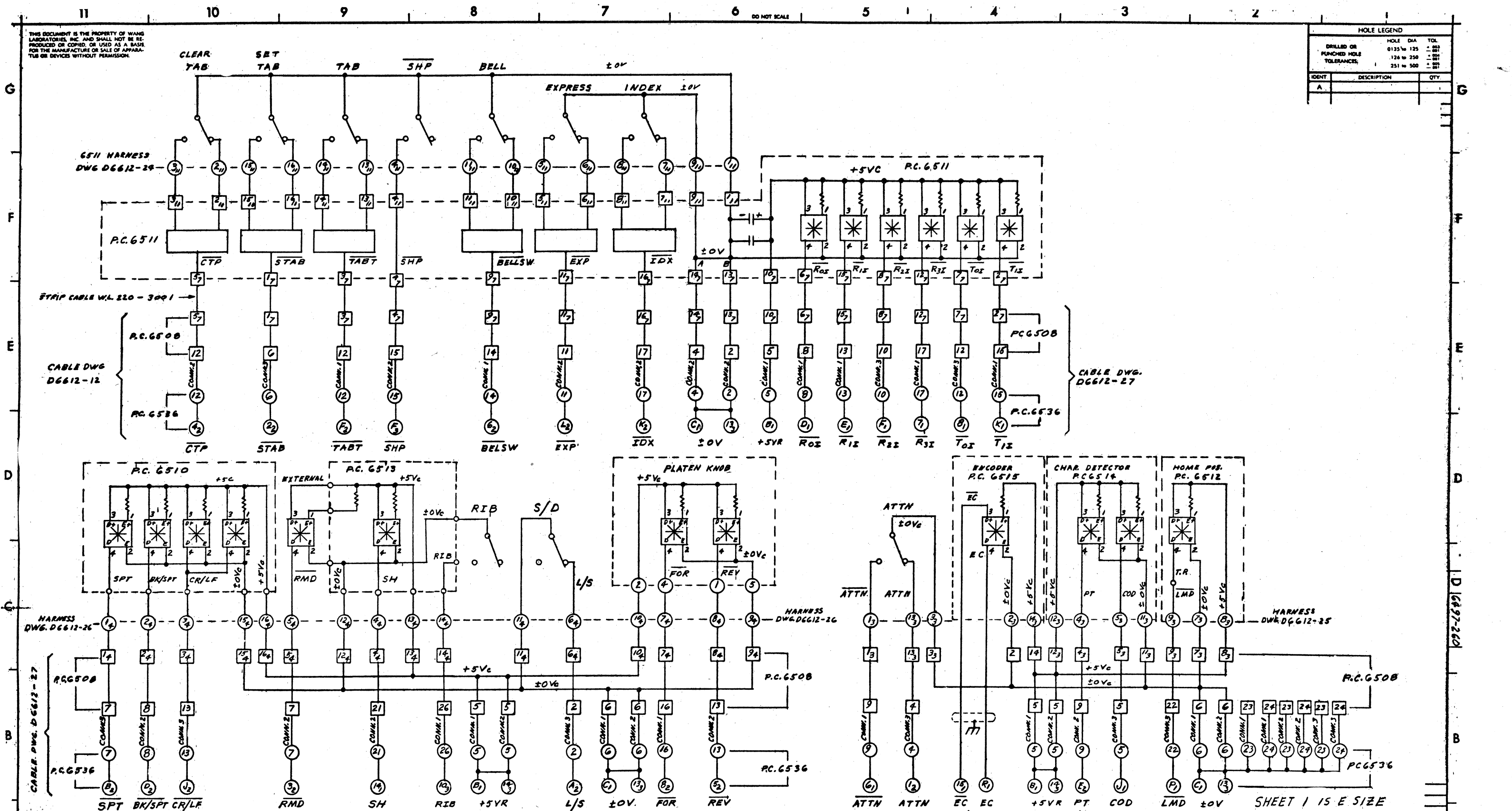

SHEET 1 IS E SIZE

WANG PART NO.	ITEM	QTY	NAME	MATERIAL	DESCRIPTION			
	FIRST USED ON	ASSY USED ON		BY	DATE	APPROVED BY	DATE	
				DWN	6/3/74	E ENGR	MLB	6-11-74
				CHK		M ENGR		
				E. C. CONTROL		MFG ENGR		
			MATERIAL	TITLE SCHEMATIC TYPEWRITER WIRING				
			MODEL NO. 1222					
			SEE ENGR SPECIFICATIONS					
			FINISH	TOL. EX. AS NOTED				
				XX ± 0.10 FRAC ± 1/64				
				XXX ± 0.05 ANG. ± 1'30" FINISH V				
				SCALE SHT 2 OF 2				
				WANG PART NUMBER	SIZE	DRAWING NUMBER	REV	
				D 6497-260				